



# TWCS

## INSET TAXIWAY CENTRELINE AND STOP BAR LIGHT



### COMPLIANCES

**ICAO:** Annex 14 - Volume I Fig. A2-12, A2-13, A2-14, A2-15, A2-16

**FAA:** L-852A-B-C-D-J-K AC150/5345-46

**IEC:** TS 61827

**NATO:** STANAG 3316

**CAA:** CAP 168

**IAAE:** TP312

### APPLICATIONS

Taxiway centreline, stopbar and intermediate holding positions for ICAO CAT I,II and III, FAA and military taxiways

### BENEFITS

- 1500 hours lamp rated life at full intensity, but over 3000 hours in field operating conditions
- Significant energy saving and stable chromaticity thanks to the use of dichroic filters
- Designed and manufactured with simplicity and easy to maintain
- No use of sealant to fix the prisms in the dome thanks to customized gaskets, making their replacement quick and easy
- No optical adjustment after lamp, filter or prism replacement
- Valve for watertightness test after overhaul
- Dome temperature less than 160°C at 6.6A

### PERFORMANCES

- 6.35 mm protrusion strongly reduces vibrations to aircrafts and to light itself, increasing its lifetime
- Dome smooth outer profile makes the light less sensitive to snowplough blades
- Bidirectional or unidirectional, 8" dia.
- Drop-forged dome and cast aluminium lower cover make the fitting sturdy, but lightweight too for ease handling in the field
- Light output practically not affected by heavy rainfall thanks to the shallow channel in front of the prism windows
- O-Ring placed outside the dome to avoid dirt deposits between light and base
- Protection degree: IP67
- Temperature range: -55°C to +55°C

### INSTALLATION

- Suitable for 8" dia. bases
- Adaptor ring for installation on 12" bases
- Specific tools available for easy and precise installation

**PHOTOMETRIC PERFORMANCES**

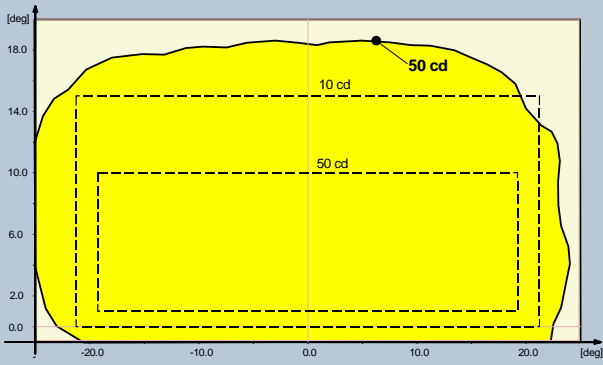

Fig. 1 ICAO A2-14 Curved Section – Yellow

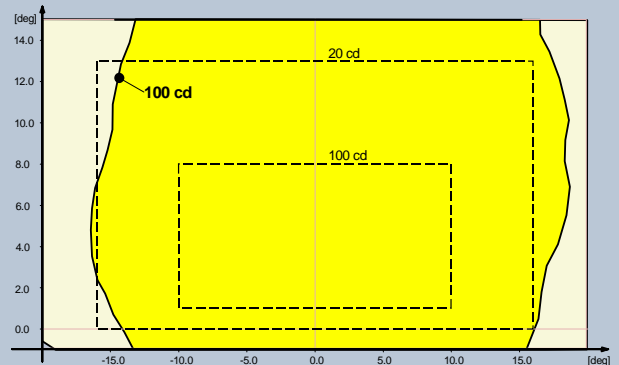

Fig. 2 ICAO A2-12 Straight Section – Yellow

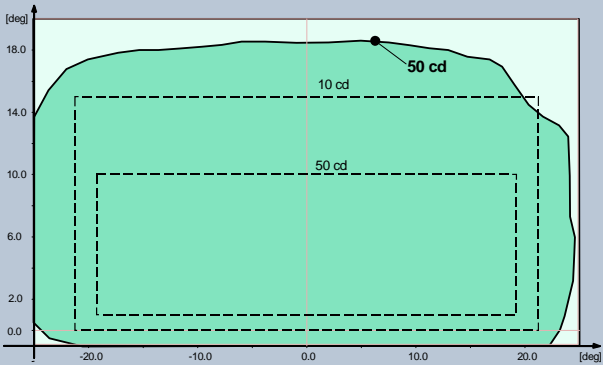

Fig. 3 ICAO A2-14 Curved Section – Green

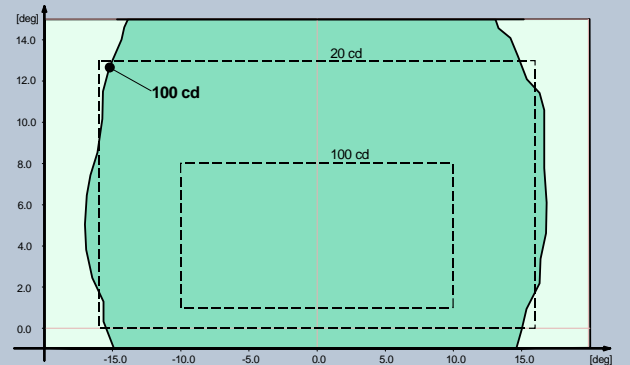

Fig. 4 ICAO A2-12 Straight Section – Green

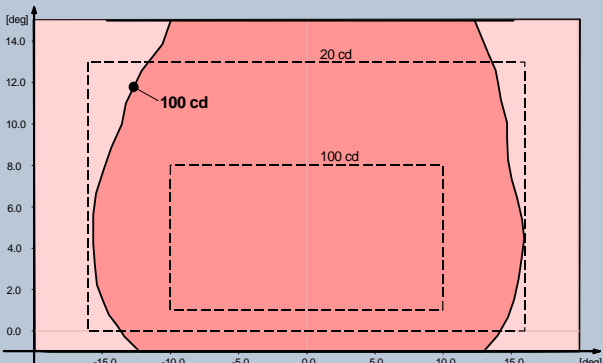

Fig. 5 ICAO A2-12 Straight Section – Red

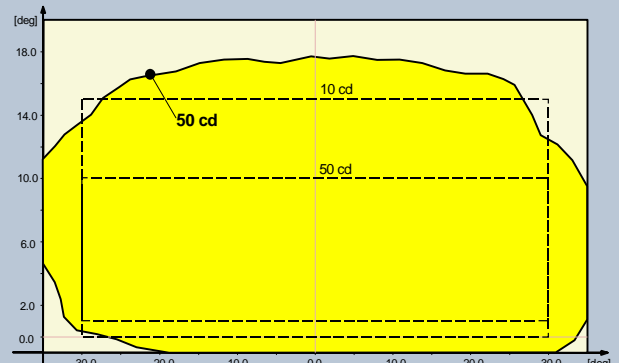

Fig. 6 FAA L-852D – Yellow

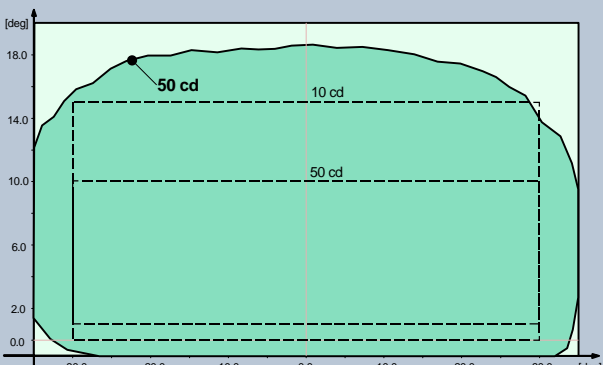
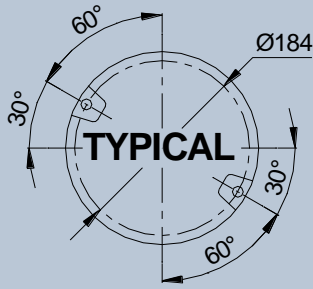
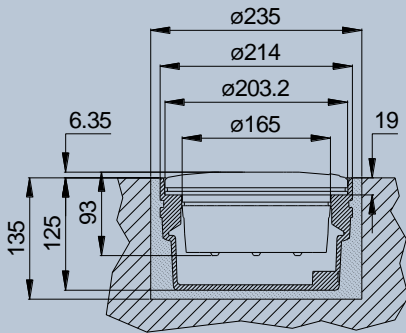

Fig. 7 FAA L-852D – Green



Light Fixture 8" dia.



Shallow Base 8" dia.

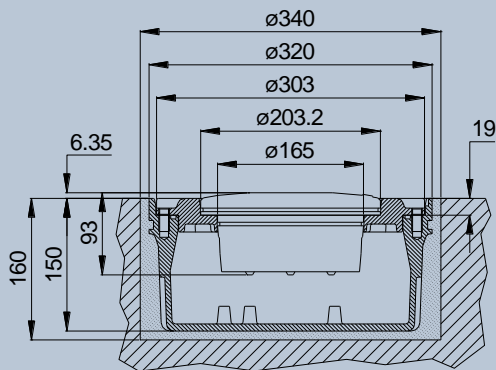

Shallow Base 12" dia.

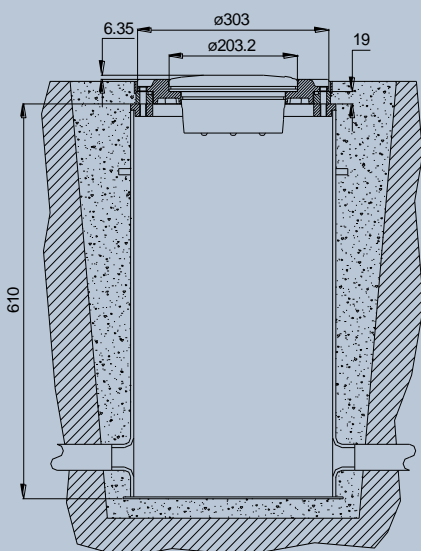

L-868 Deep Base 12" dia.

**TWCS- A - I - GG - 030 - O - F**

Basic P/N: \_\_\_\_\_

Use Code: \_\_\_\_\_  
(Refer to TABLE A)

Compliance: \_\_\_\_\_

- I = ICAO CAT III
- S = STANAG and ICAO CAT I - II
- F = FAA

Colour(Side A)/(Side B)\*: \_\_\_\_\_

- G = Green
- Y = Yellow
- R = Red
- C = White (L-852D only)
- X = Screened
- M = Blank (unidirectional dome)\*\*

Lamps: \_\_\_\_\_

- 030 = 1x30W 6.6A with reflector
- 045 = 1x48W 6.6A with reflector

Mounting Assembly: \_\_\_\_\_

- O = No Mounting Assembly
- R = Adaptor Ring 8"-12"

Options: \_\_\_\_\_

- F = Fuse Cutouts

\* For curved sections it's necessary to specify the colour of each side, "A" and "B", due to the fixture toe-in

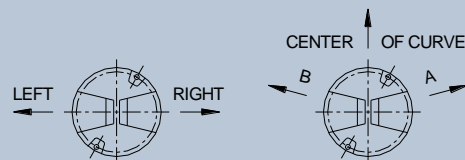

Straight and Curved Section Orientation

\*\* The not-finished "M" side, on straight sections, is always side "B"

TABLE A

USE	I = ICAO CAT III	S = ICAO CAT I-II	F = FAA
A	Fig. A2.12 straight before and after curves	Fig. A2.15 straight	L-852A
B			L-852B
C	Fig. A2.13 straight		L-852C
D			L-852D
W	Fig. A2.14 curved	Fig. A2.16 curved	
K			L-852K
J			L-852J

**RENEWAL PARTS FOR LIGHT UNIT**

- 1 Dome with prisms and gaskets
- 2 O-Ring for dome
- 3 O-Ring for lower cover
- 4 Prism gasket
- 5 Prism
- 6 Filter
- 7 Aluminium screen for unidirectional light
- 8 Teflon filter-holder
- 9 Filter-holder box
- 10 Mounting plate
- 11 Lampholder
- 12 Vibration damping block with hardware
- 13 Lamp
- 14 Fuse cutout
- 15 Insulated strip with hardware
- 16 Lower cover with plug and valve
- 17 O-Ring for base
- 18 Valve for watertightness test
- 19 FAA L-823 plug

Refer to the relevant technical manual for the complete list of the available spare parts

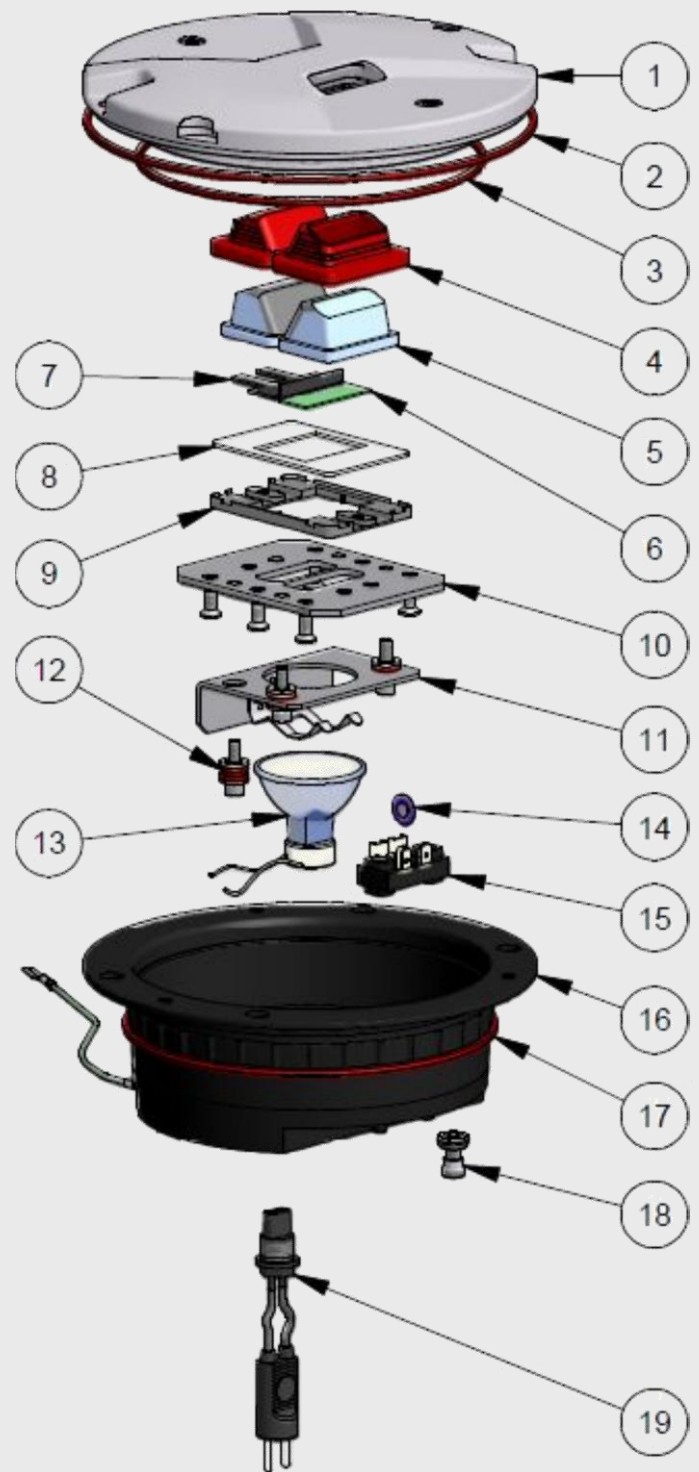
**ACCESSORIES**

- |          |  |
|----------|--|
| 315.1230 | Base L-868 type, class IA, size B, 24" deep*   |
| 315.1420 | Flange ring with pavement dam for L-868 base, size B, with O-Ring and bolts                  |
| 152.5251 | Shallow base, 8" dia., one cable lead, with hardware   |
| 152.8110 | Shallow base, 12" dia., one cable lead, with gasket and hardware                             |
| 152.6116 | Adaptor Ring 8"-12" dia. complete with hardware  |
| 712.1034 | Setting material for shallow base, 10 lt   |
| 712.1035 | Quartz for shallow base, 25 kg   |
| 332.4301 | Positioning jig for 8"-12" dia. shallow base, without optical device                         |
| 332.4351 | Optical device for positioning jig to allow a very precise light unit orientation            |
| 332.4330 | Watertight/shockproof plastic case complete with positioning jig for base and optical device |
| 332.4140 | Lifting tool (2 pieces to work properly)   |

\* Sectional bases may be required depending upon the paving technique

For any information about isolating transformers and connectors, please see the specific catalogue pages

**Shipping Weights and Volumes**

	Light Unit	Shallow base	Light Unit & Adaptor Ring
Weight (kg)	2.9	3.2	6.05
Volume (m <sup>3</sup> )	0.007	0.007	0.013

We reserve the right to change the design or specification data without notice

UC-PU-0104\_EN-Rev.E